

# Hand Pallet Truck



## Hand Pallet Truck HPT 20/25/30

### Robust Design

Grooved forks are punched by heavy pressure to make them much stronger than standard flat fork

### Simple Adjustments

Unique push rod design helps in easy adjustment of forks for better stability

### Precision Quality

Fully automatic robot welding chassis provides precision, consistency, reliable quality & longer life

### Easy Maintenance

Fully automatic robot welding chassis provides precision, consistency, reliable quality and longer life

# Hand Pallet Truck (HPT)



Well designed opening space for loading wheel provides better protection for parts including wheel, push rod & wheel fork



Tough chassis design provides stability and reliability. The extra supporting rod gives longer chassis life



Bridge plate for 2.0T; Half length stiffener for 2.5T; Full length stiffener for 3T



Unique push rod design helps in easy adjustment of forks for better stability



Grooved forks punched by heavy pressure makes them much stronger than standard flat fork

Model			HPT20	HPT25	HPT30
<b>Feature</b>					
1.1	Capacity	kg	2000	2500	3000
1.2	Pump Type		DB Casted Pump	DF Casted Pump	DF Casted Pump
<b>Wheel</b>					
2.1	wheel(drive/load) Type		PU/RU/Nylon	PU/RU/Nylon	DF Casted Pump
2.2	size of steering wheel	ΦD mm	160*50	180*50 200*50	180*50 200*50
2.3	size of Loading wheel (single wheel)	ΦD mm	70*80	74*93 80*93 800*93	74*93 80*93 80*93
2.4	size of Loading wheel (double wheel)	ΦD mm	70*60	74*93 80*93 800*93	74*93 80*93 80*93
<b>Dimensions</b>					
3.1	lifting weight	h mm	115	115	115
3.2	max. fork lifting height	H mm	190	195 200 200	195 200 200
3.3	lowered height of fork	H1 mm	75	75 85 85	75 85 85
3.4	fork outside distance	W mm	520/550/685	520/550/685	520/550/685
3.5	fork length	L mm	900/1100/1150/1220	900/1100/1150/1220	900/1100/1150/1220
3.6	fork width	S mm	150	160	160
3.7	steel thickness (After painting)	mm	2.5	3	3.75
3.8	weight	kg	40-57	61-68	71-79

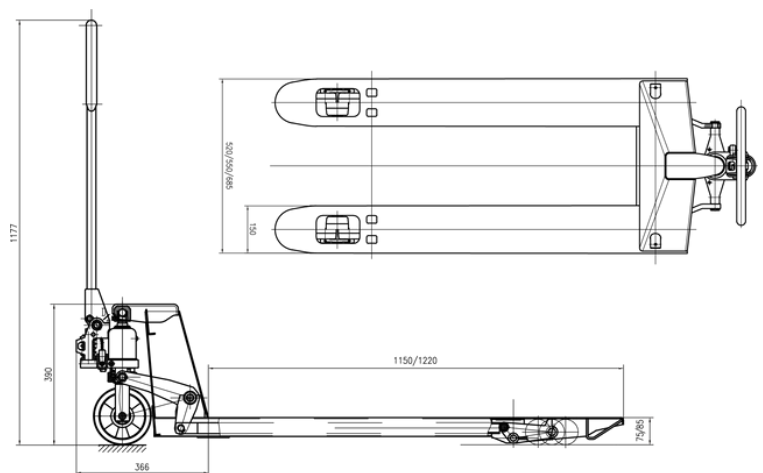
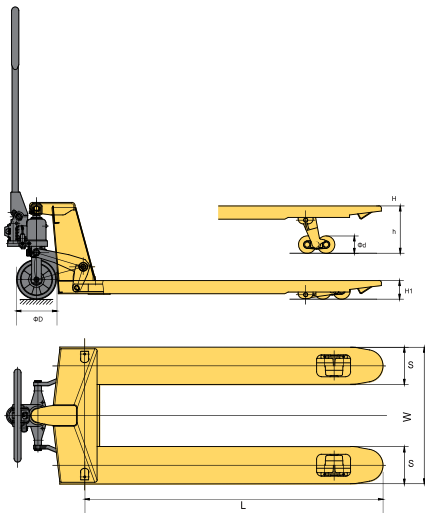

The company reserves the right to make technical alterations without prior notification.  
[www.signode.com](http://www.signode.com) For any queries in India, please contact us at  
[info.india@signode.com](mailto:info.india@signode.com)